

GASOLINE GENERATOR

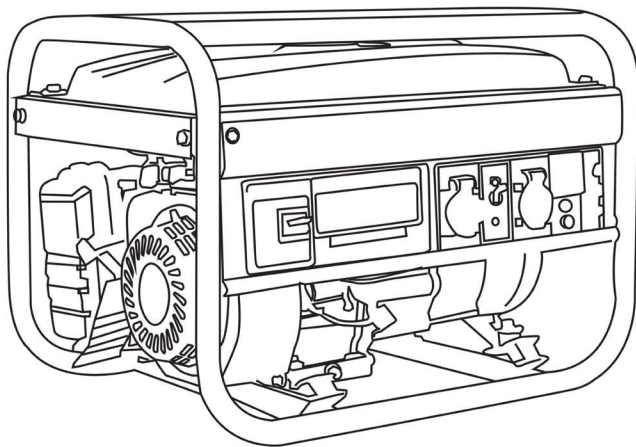

OWNER'S MANUAL

Gasoline generator

User's manual

I. Safety instructions

1. Do operate it at a well ventilated place, for the exhaust contains poisonous carbon monoxide.. (Fig 1)
2. Do not operate it under wet conditions. (Fig 2)
3. Do not connect it to a household circuit without a guidance. (Fig 3)
4. The set must be kept away from the flammable materials at least one meter. (Fig 4)
5. Smoking and igniting and sparking are prohibited while refilling. (Fig 5)
6. Stop the generator set while refilling. (Fig 6)

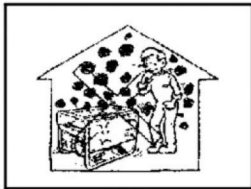

Fig1

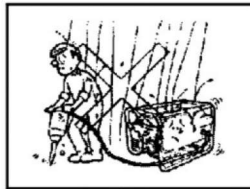

Fig2

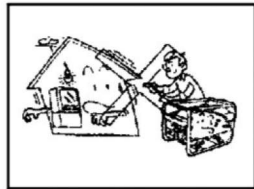

Fig3

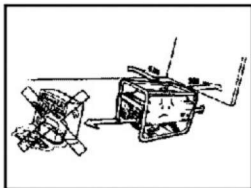

Fig4



Fig5

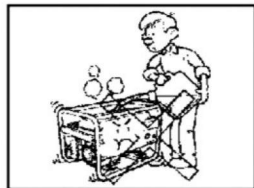

Fig6



Fig7

7. Do not overflow the fuel while refilling. Otherwise, wipe off the overflowed fuel (Fig 7)
8. Keep the set in horizontal position while running.
9. Keep the children and pets away from the set while running.
10. Do not touch muffler or any over-hot parts to prevent injuring when the set is running or just stopped.

II. Description of components

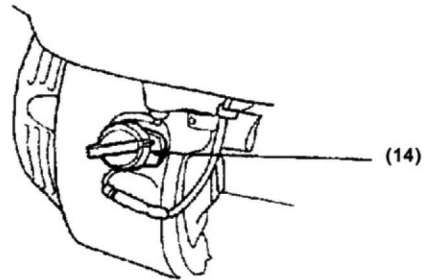
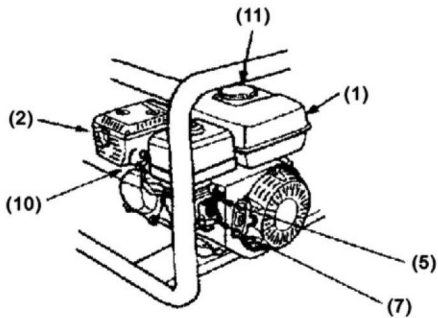
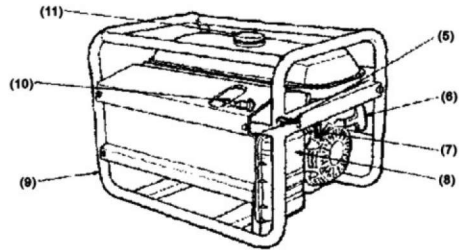
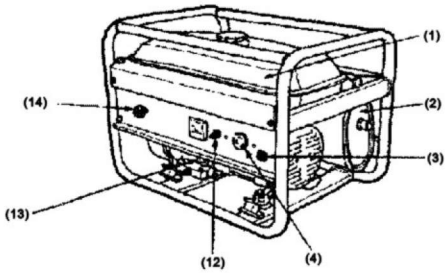

- 1) Fuel tank
- 2) Exhaust muffler
- 3) Grounding terminal (for QS/QH type)
- 4) AC receptacle
- 5) Carburetor valve
- 6) Starter handle
- 7) Fuel valve
- 8) Air cleaner
- 9) Framework
- 10) Spark plug
- 11) Fuel tank cap
- 12) AC breaker
- 13) Oil filler cap
- 14) Engine switch

III. Pre-operation checks

Be sure to perform the following checks before starting the generating set:

- 1) Check whether the generator set is on a flat surface.
- 2) Check the level of engine oil
 1. Screw off the oil filter cap and clean the measure mark with a clean rag (Fig 8)
 2. Insert the oil filler cap without screwing.
 3. If the oil level is below the limit, refill the oil till the high limit.
 4. Screw on the oil filler cap.

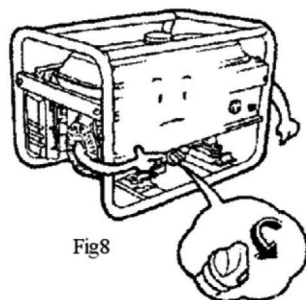
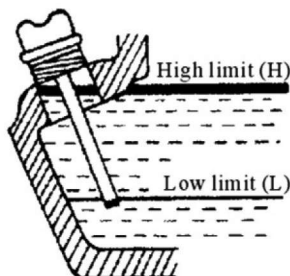

3) Check the fuel level

1. Open the fuel tank (Fig 9).
2. Check the fuel level, refill if the level is too low.
3. Refill the fuel till the shoulder of the fuel filter.
4. Tighten the fuel tank cap.

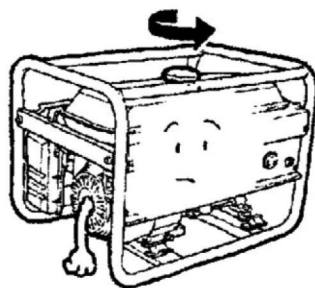
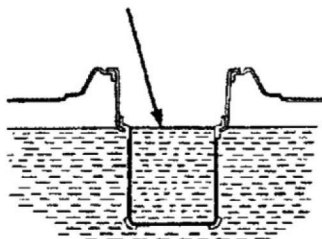

4) Check the air cleaner

1. Remove the clip and dismount the case of air cleaner. (QH type).
Unscrew the nut and remove the cover of air cleaner. (Q/QS type).

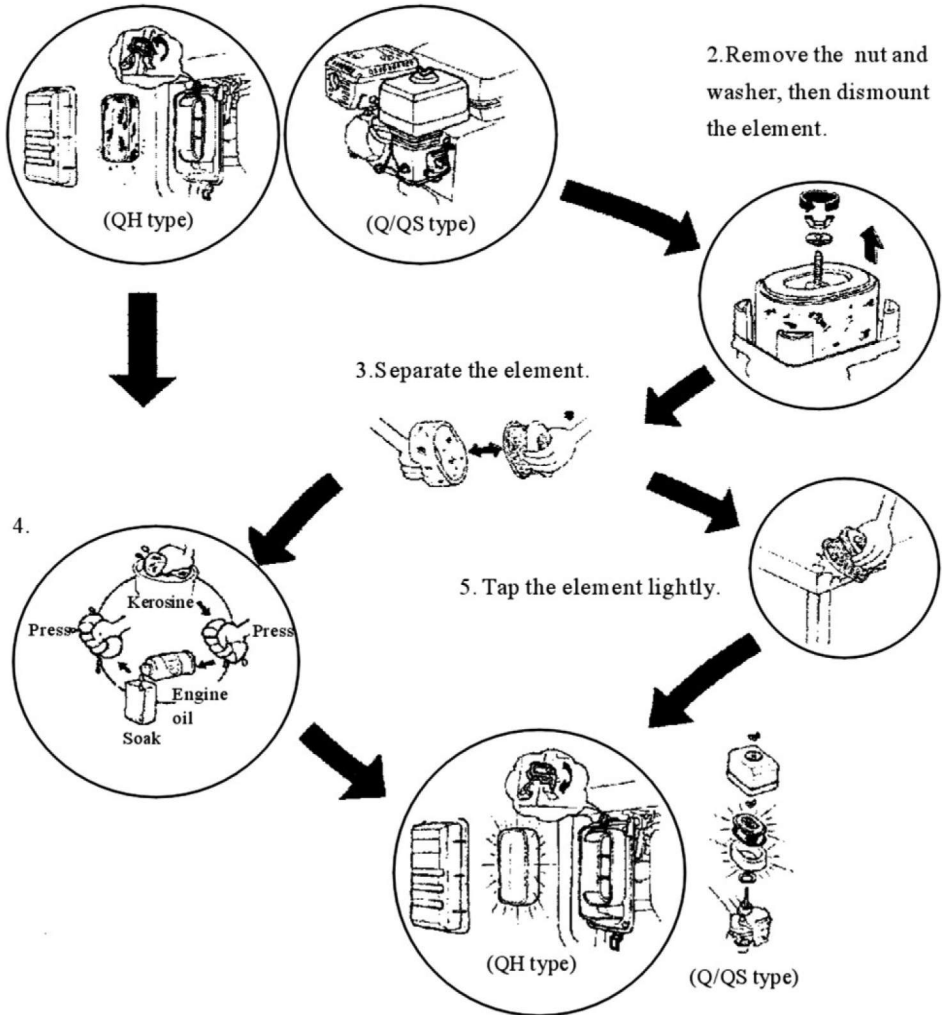

IV. Starting the generator set

1. Disconnect any load from AC receptacle
And switch off AC breaker

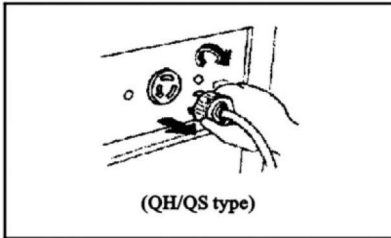

2. Set the fuel valve to ON position

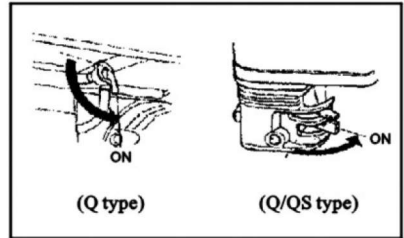

3. Set the choke lever to CHOKE position.

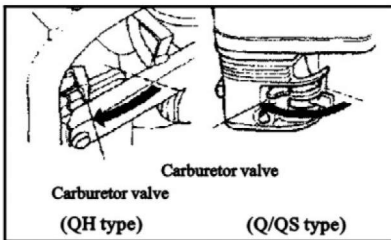

4. Turn the engine switch to ON position.

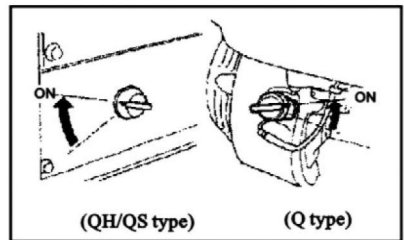

5. Pull the starter handle slowly until you
Feel the resistance, then pull it by force.

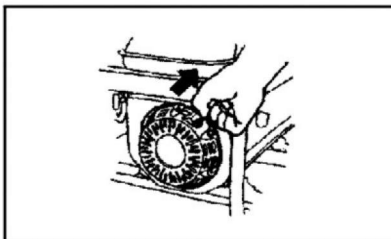

6. When the engine is heating up,
set the choke lever to OFF
position.

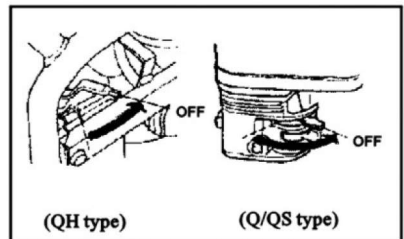

V. Usage of the generator set

1) In order to keep the generator set in the best mechanical and electrical condition, please follow the below items:

1. Please ground the grounding terminal of the set to prevent any false operating. Regarding Q type set, grounding can be performed from the grounding tap hole which is on the front (back) cover of the engine.

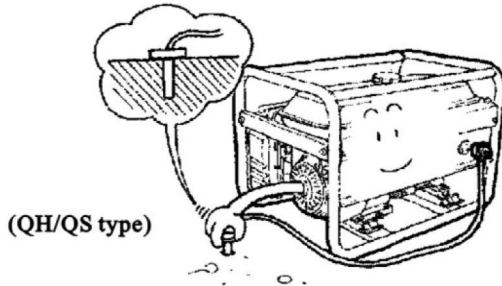

2. Check whether AC output voltage and frequency meet the technical specifications.
3. If the generator set will be connected with more than two loads, please connect them from the high starting current in turn.
4. Connecting the set to the household circuit must be performed by the professional. Check whether the load is correctly connected to prevent the generator set from damage or fire.

○ Good

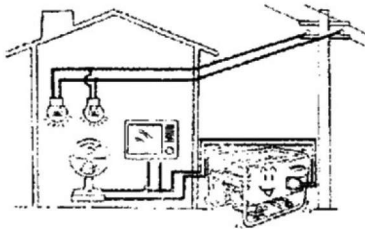

✗ Forbidden

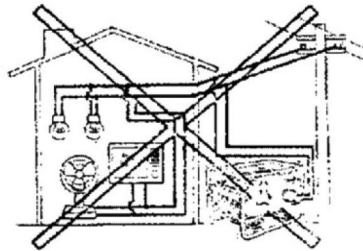

○ Good

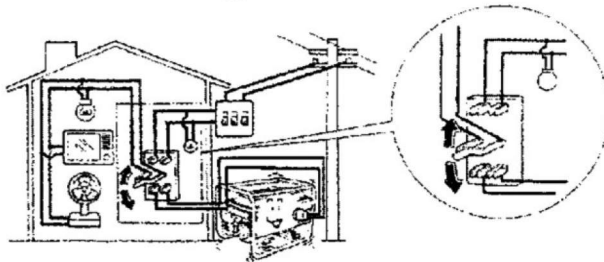

2) Application of AC

1. Starting the generator set.

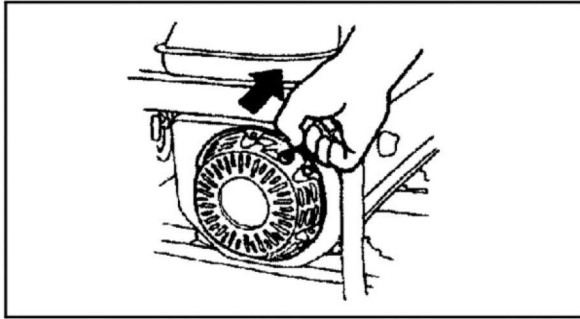

2. Connecting the load.

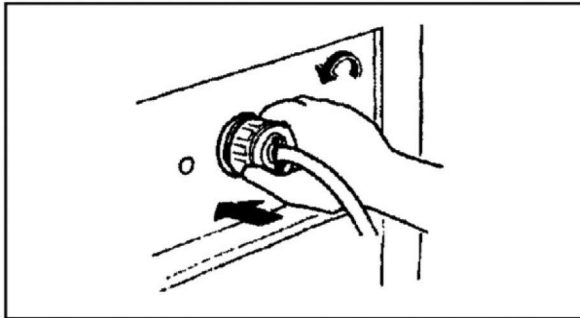

3. Switch on the AC breaker.

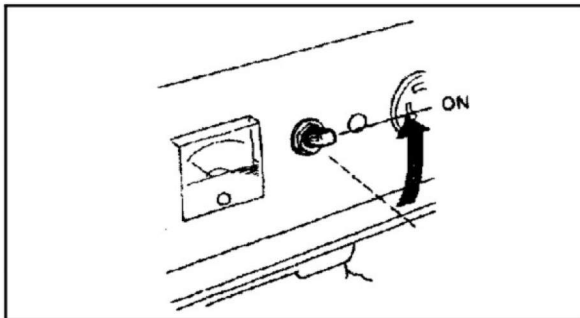

VI. Stopping the generator set

1. Switch off the AC breaker.

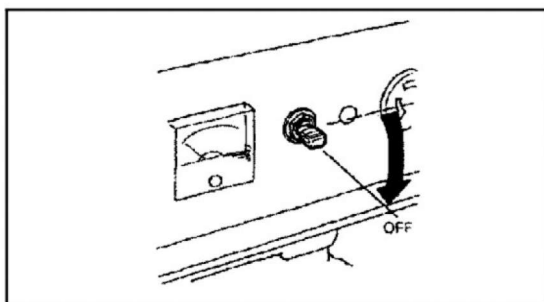

2. Switch off the engine.

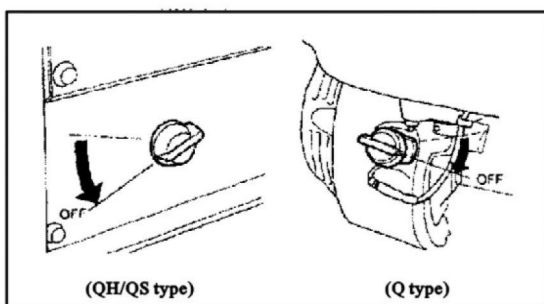

3. Close the fuel valve.

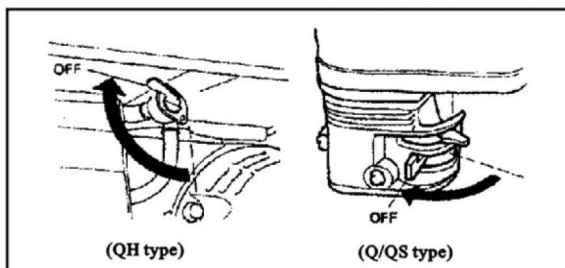

Note: If you want to stop the engine in emergency, please set the engine switch on OFF position.

VII. Maintenance

Periodical inspection and maintenance are very important for keeping your generator set in good working condition.

Be sure to turn off the set before performing maintenance, however if it's necessary to run the set, performing must be carried out at a ventilated place, for the exhaust contains poisonous carbon monoxide.

MAINTENANCE TIME		EVERY TIME	FIRST MONTH OR 20 HRS	THIRD MONTH OR 50 HRS	EVERY SIX MONTHS OR 100 HRS	EVERY YEAR OR 300 HRS
ITEM						
Engine oil	Check	○				
	Replace		○			
Air cleaner	Check	○			○	
	Clean			○		
Fuel strainer cup	Clean				○	
Spark plug	Clean				○	
	Adjust					
Air valve clearance	Clean					○ (2)
	Adjust					
Cylinder head cover	Clean					○ (2)
Fuel tank	Check	Every two years				
Oil pipes	Clean					

Note:

1. Shorten maintenance intervals if the generator set is operated in dirty area.
2. The above mentioned items must be performed with assistance of your agent.

1. Replace engine oil

1) Open the oil filler cap.

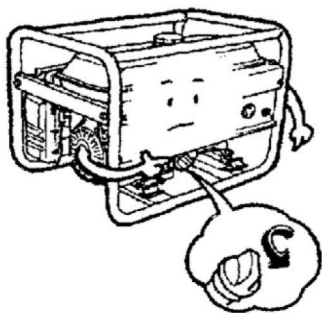

2) Screw off the drain screw plug to Drain off the engine oil.

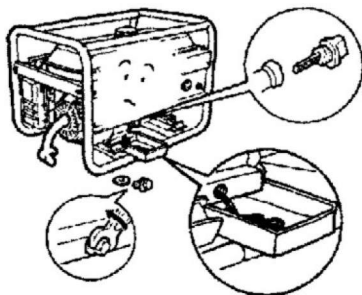

3) Reassemble the drain screw plug

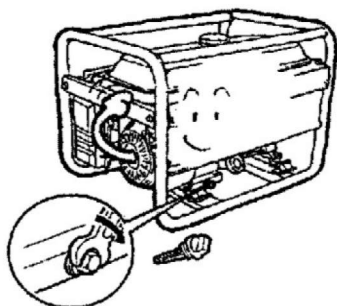

4) Refill engine oil until the upper Limit level of the oil filler cap.

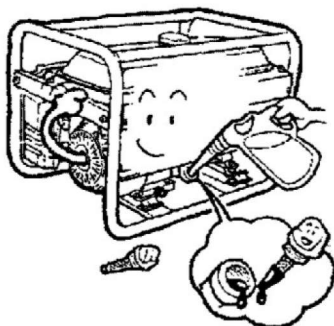

5) Reassemble the oil filler cap.

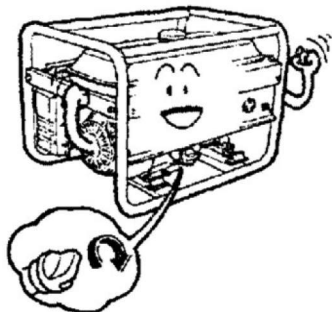

Recommend engine oil: Engine oil for 4-stroke gasoline engine SAE10W-30

2. Air cleaner
(see 3-4)

3. Spark plug

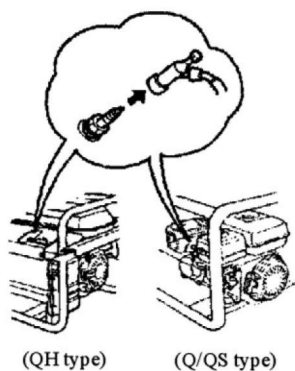

1. Dismount the
spark plug cover.

2. Dismount the
spark plug

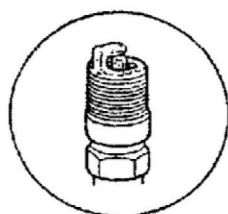

0.7 - 0.8 mm

3. Clean the carbon

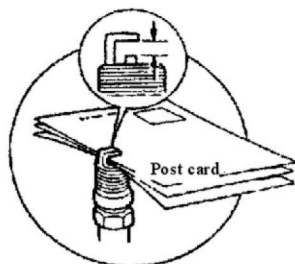
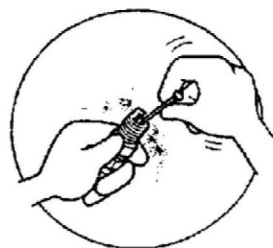

4. Measure the clearance of the
spark plug

5. Reassemble the spark
plug cover.



4. Maintenance of the fuel filter

Set the fuel valve to OFF position and dismantle the fuel strainer cup.

(1.) QH type

Dismount the fuel filter.

Blow it from the opposite direction
Of the arrow.

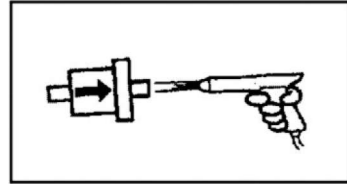
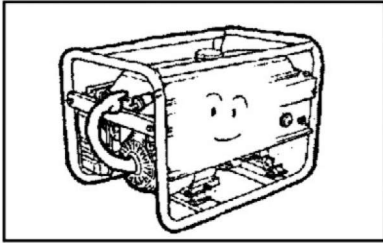

(2.) Q/QS type

Dismount the strainer cup.

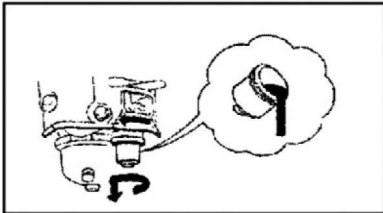

Clean the strainer cup thoroughly.

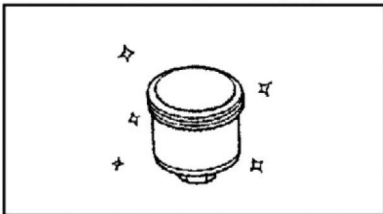

Reassemble the new rubber washer and strainer cup tightly.

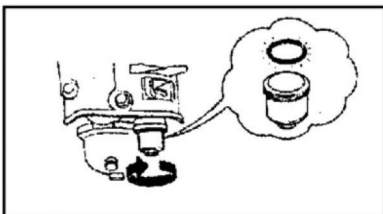

VIII. Storage

1. Switch off the fuel valve and remove the fuel filter cover.
Drain off the gasoline from the fuel strainer cup.
(Only for Q/QS type)

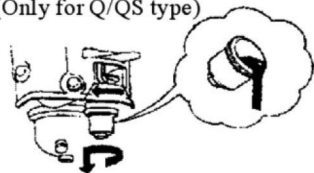

2. Open the fuel valve.
Drain off gasoline from fuel tank.
(Only for Q/QS type)



3. Replace the rubber washer, then tighten the strainer cup.
(Only for Q/QS type)



4. Remove the drain screw plug and drain off gasoline from the carburetor.

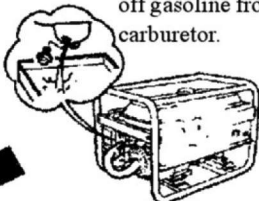

5. Remove the filler cap and drain screw plug, then drain off the engine oil.

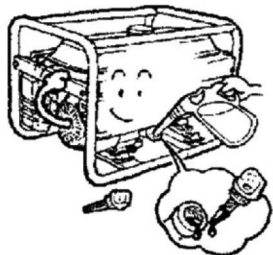

6. Reassemble the drain screw plug.

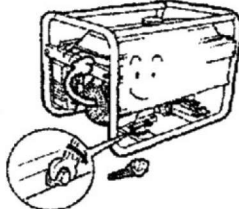

7. Refill engine oil until the high limit of the filler cap.

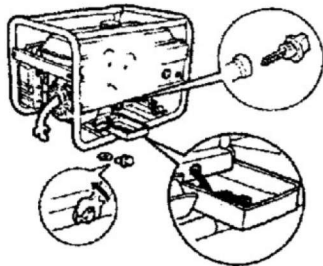

8. Pull the starter handle slowly until you feel resistance.

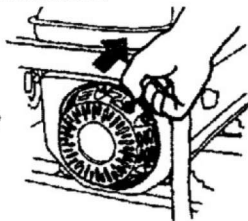

IX. Troubleshooting

1. The generator set cannot be started.
position

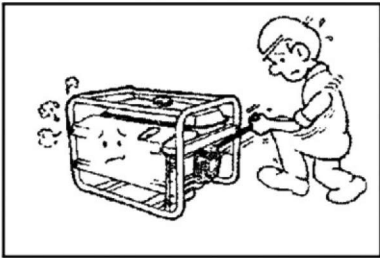

2. Whether the engine switch is at the OFF position

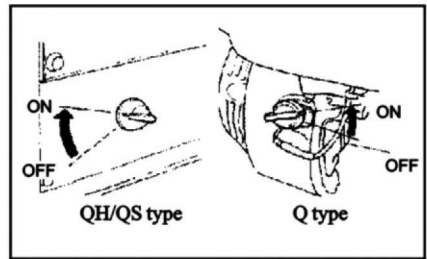

3. Check the engine oil.

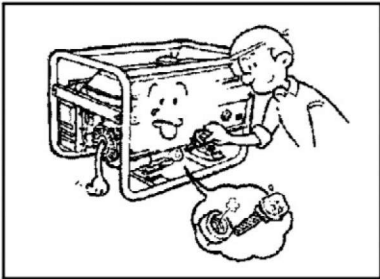

4. Check the fuel.

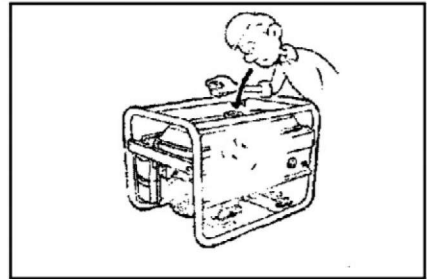

5. Dismount the spark plug.

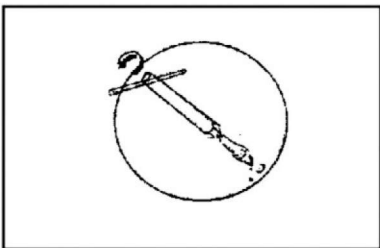

6. Check the spark plug.

